

---

# TRANSFER

	Page
TROUBLESHOOTING .....	TF-2
TRANSFER .....	TF-3
Removal of Transfer .....	TF-3
Components .....	TF-5
Disassembly of Transfer .....	TF-7
Inspection of Transfer Components .....	TF-12
Assembly of Transfer .....	TF-20
Installation of Transfer .....	TF-25

**TROUBLESHOOTING**

<b>Problem</b>	<b>Possible cause</b>	<b>Remedy</b>	<b>Page</b>
Hard to shift or will not shift	Splines on input shaft dirty or burred Transfer faulty	Repair as necessary Disassemble and inspect transfer	TF-3 TF-3
Transfer jumps out of gear	Transfer faulty	Disassemble and inspect transfer	TF-3

A00837

# TRANSFER

## REMOVAL OF TRANSFER

1. DISCONNECT BATTERY CABLE FROM NEGATIVE TERMINAL
2. REMOVE STARTER UPPER MOUNTING NUT

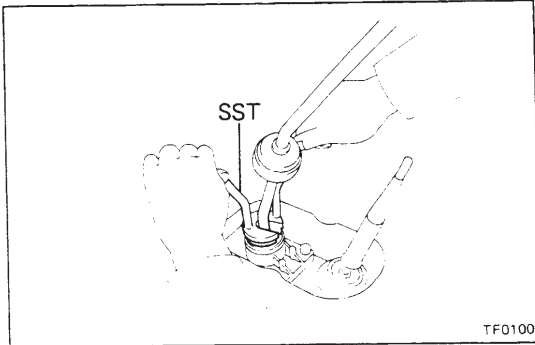

3. REMOVE TRANSMISSION SHIFT LEVER FROM INSIDE OF VEHICLE

(22R Engine Vehicle)

Using SST, pull up the shift lever cup and pull out the shift lever from the transmission.

SST 09305-20012

(22R-EC Engine Vehicle)

(a) Pull up the shift lever cup.

(b) Remove the four bolts and pull out the shift lever from the transmission.

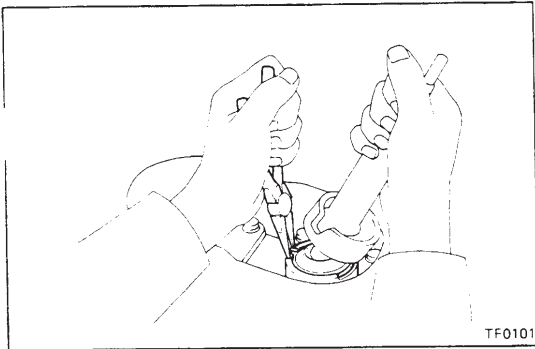

4. REMOVE TRANSFER SHIFT LEVER FROM INSIDE OF VEHICLE

Using pliers, remove the snap ring and pull out the shift lever from the transfer.

5. RAISE VEHICLE AND DRAIN TRANSMISSION AND TRANSFER

**CAUTION:** Be sure the vehicle is securely supported.

6. DISCONNECT FRONT AND REAR PROPELLER SHAFTS  
(See page PR-3)

7. DISCONNECT SPEEDOMETER CABLE, BACK-UP LIGHT SWITCH CONNECTOR AND TRANSFER INDICATOR SWITCH CONNECTOR

8. REMOVE EXHAUST PIPE CLAMP AND EXHAUST PIPE

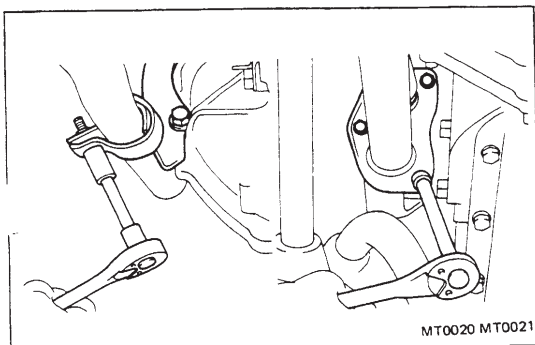

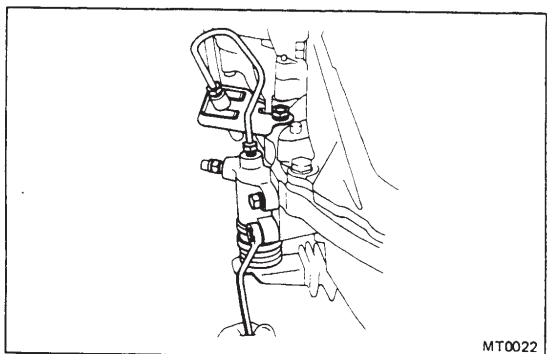

**9. REMOVE CLUTCH RELEASE CYLINDER, TUBE BRACKET AND STARTER LOWER MOUNTING BOLT**

Remove the mounting bolts and lay the starter and release cylinder alongside the engine.

NOTE: Do not disconnect the clutch line.

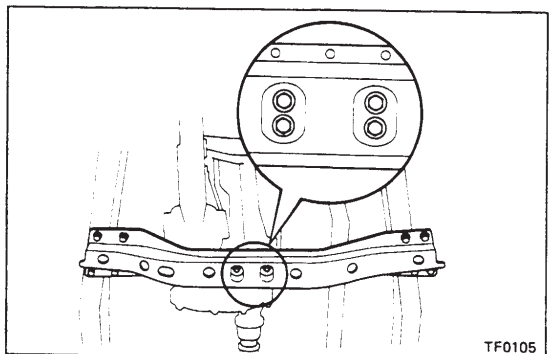

**10. REMOVE FRAME CROSSMEMBER NO.2 FROM SIDE FRAME**

- (a) Remove the four bolts from the engine rear mounting.
- (b) Raise the transmission slightly with a jack.
- (c) Remove the four bolts from the side frame and remove the frame crossmember No.2.

**11. PLACE PIECE OF WOOD BETWEEN ENGINE OIL PAN AND FRONT AXLE**

**12. LOWER TRANSMISSION WITH TRANSFER**

**13. REMOVE EXHAUST PIPE BRACKET AND STIFFENER PLATE BOLTS**

**14. REMOVE REMAINING TRANSMISSION BOLTS**

**15. REMOVE TRANSMISSION WITH TRANSFER**

- (a) Draw out the transmission with the transfer toward the rear.
- (b) Lower the transmission with the transfer front and remove it from the vehicle.

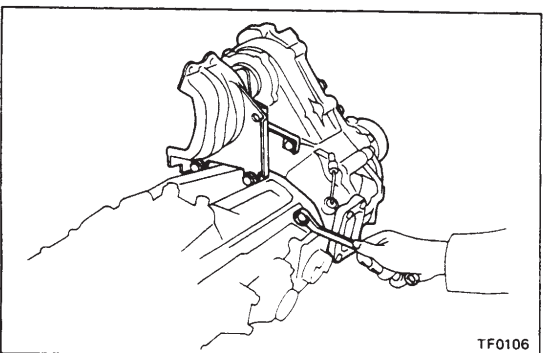

**16. REMOVE ENGINE REAR MOUNTING**

**17. REMOVE PROPELLER SHAFT UPPER DUST COVER AND TRANSFER FROM TRANSMISSION**

- (a) Remove the dust cover bolt from the bracket.
- (b) Remove the transfer adapter rear mounting bolts.
- (c) Pull the transfer straight up and remove it from the transmission.

NOTE: Take care not to damage the adapter rear oil seal with the transfer input gear spline.



COMPONENTS (Cont'd)

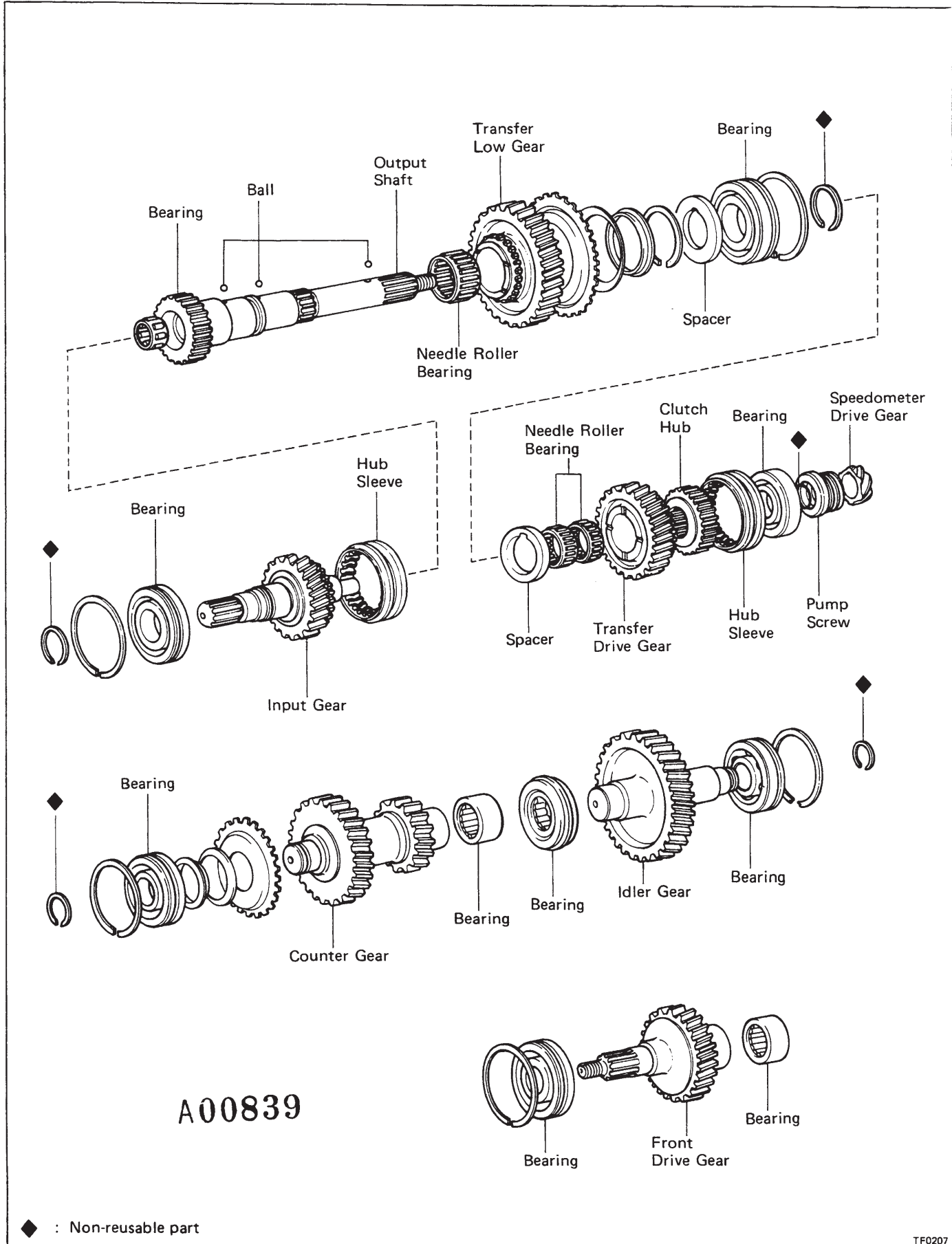

A00839

## DISASSEMBLY OF TRANSFER

1. REMOVE SPEEDOMETER DRIVEN GEAR
2. REMOVE TRANSFER INDICATOR SWITCH

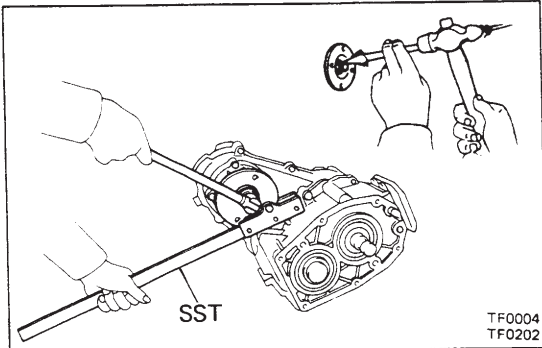

### 3. REMOVE FRONT COMPANION FLANGE

- (a) Using a hammer and chisel, loosen the staked part of the nut.
- (b) Using SST to hold the flange, remove the nut and washer.

SST 09330-00020

- (c) Remove the companion flange.

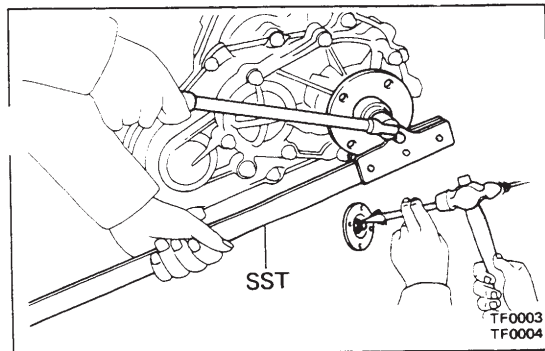

NOTE: If the companion flange is difficult to remove, use SST.

### 4. REMOVE REAR COMPANION FLANGE

- (a) Using a hammer and chisel, loosen the staked part of the nut.
- (b) Using SST to hold the flange, remove the nut and washer.

SST 09330-00020

- (c) Remove the companion flange.

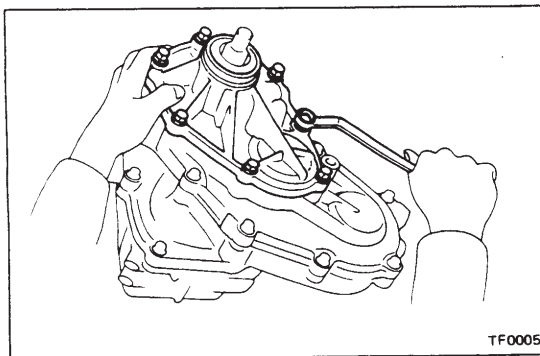

### 5. REMOVE EXTENSION HOUSING

Remove the seven bolts and remove the extension housing.

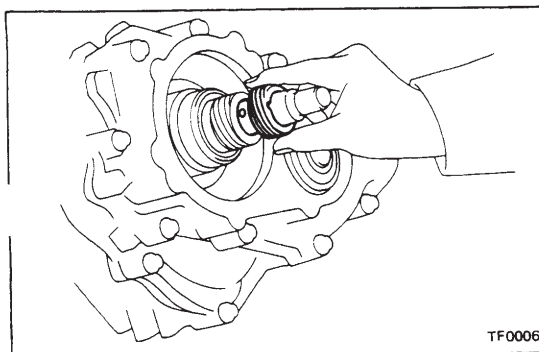

### 6. REMOVE SPEEDOMETER DRIVE GEAR, STEEL BALL, OIL PUMP SCREW AND BEARING

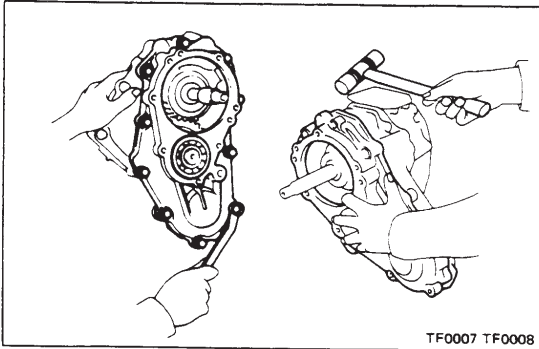

## 7. REMOVE REAR CASE

- (a) Remove the ten bolts.
- (b) Using a plastic hammer, remove the rear case with the idler gear.

**NOTE:** Hold the front case so the rear does not descend. If it descends, the clutch hub and steel ball may fall out.

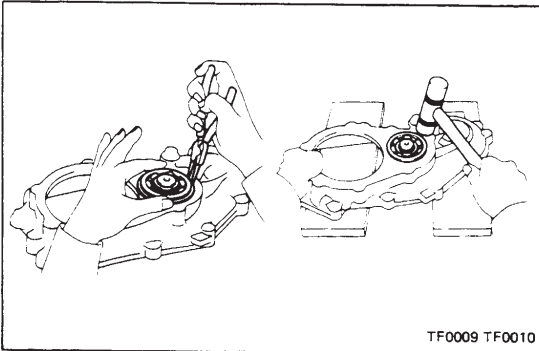

## 8. REMOVE IDLER GEAR FROM REAR CASE

- (a) Using snap ring pliers, remove the snap ring.
- (b) Using a plastic hammer, tap out the idler gear from the rear case.

**NOTE:** Place the rear case on something soft such as wooden blocks.

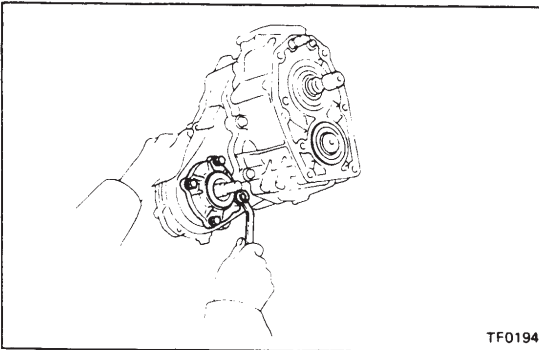

## 9. REMOVE BEARING RETAINER

Remove the four bolts and remove the bearing retainer.

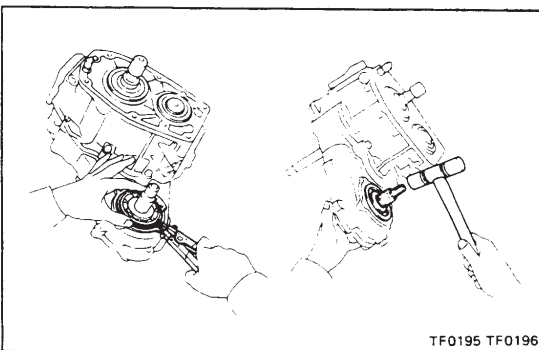

## 10. REMOVE FRONT DRIVE GEAR

- (a) Using snap ring pliers, remove the snap ring.
- (b) Using a plastic hammer, tap out the front drive gear from the front case.

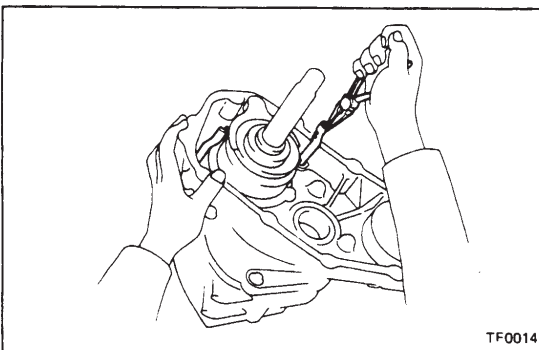

## 11. REMOVE OIL PIPES

Using pliers, remove the two oil pipes.

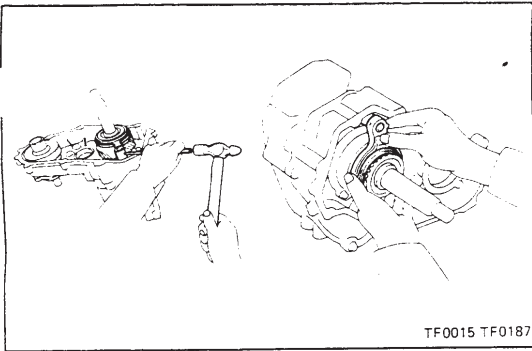

**12. REMOVE SHIFT NO.1 FORK AND CLUTCH SLEEVE**

- (a) Shift the fork shafts to the high-low position.
- (b) Using a pin punch and hammer, drive out the slotted spring pin.
- (c) Remove the shift No.1 fork together with the clutch sleeve.

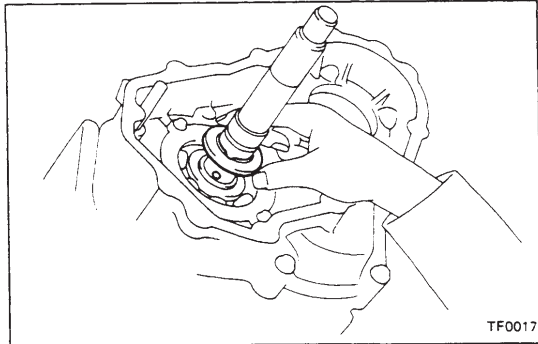
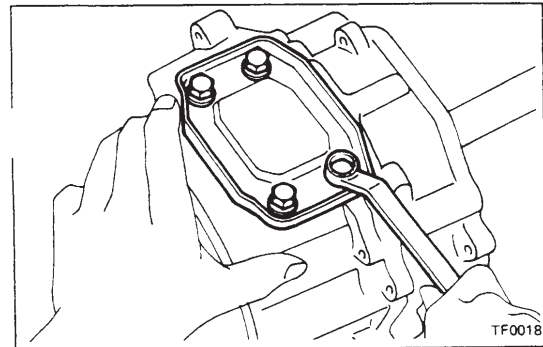
**13. REMOVE CLUTCH HUB AND TRANSFER DRIVE GEAR****14. REMOVE NEEDLE ROLLER BEARING, NO.2 SPACER AND STEEL BALL****15.-1 (22R Engine Vehicle)****REMOVE TRANSFER CASE COVER**

Remove the four bolts and remove the transfer case cover and gasket.

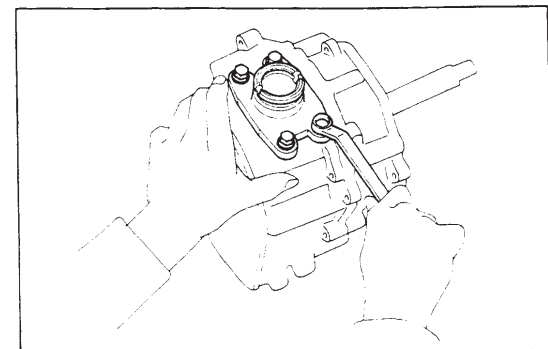
**15.-2 (22R-EC Engine Vehicle)****REMOVE SHIFT LEVER RETAINER**

Remove the four bolts and remove the shift lever retainer and gasket.

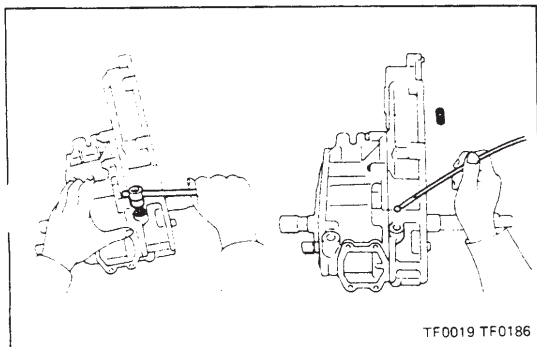
**16. REMOVE STRAIGHT SCREW PLUGS, SPRINGS AND LOCKING BALLS**

- (a) Using SST, remove the plug on the right side.  
SST 09313-30021
- (b) Using a magnetic finger, remove the spring and ball.
- (c) Remove the plug, spring and ball on the left side in the same procedure.

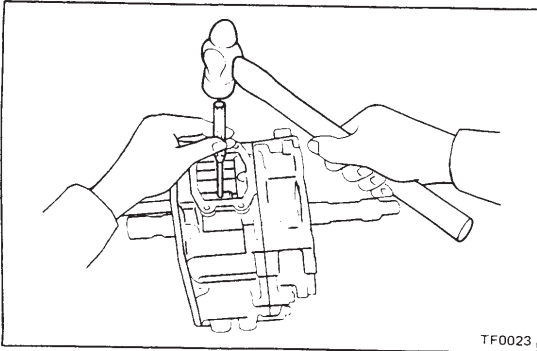

TF0023

**17. REMOVE SLOTTED SPRING PINS**

Using a pin punch and hammer, drive out the slotted spring pins from shift fork shaft.

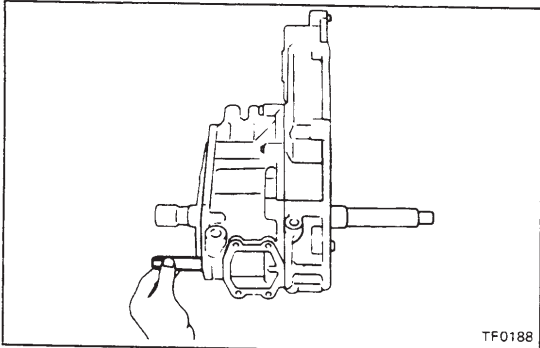

TF0188

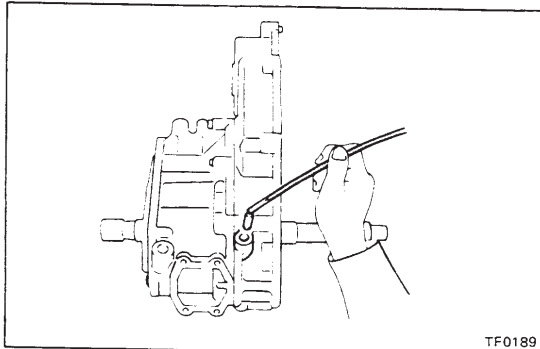
**18. REMOVE FRONT DRIVE SHIFT FORK SHAFT**

TF0189

**19. REMOVE INTERLOCK PIN**

Using a magnetic finger, remove the interlock pin.

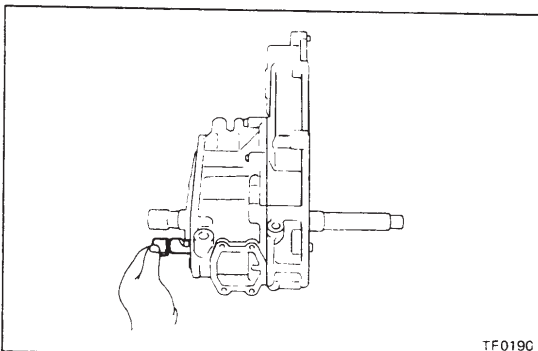

TF0190

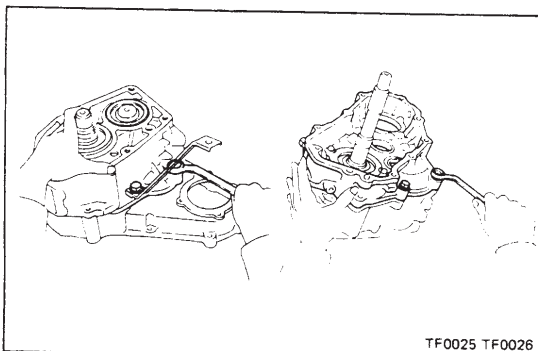
**20. REMOVE HIGH-LOW SHIFT FORK SHAFT**

TF0025 TF0026

**21. REMOVE FRONT CASE**

(a) Remove the four bolts.

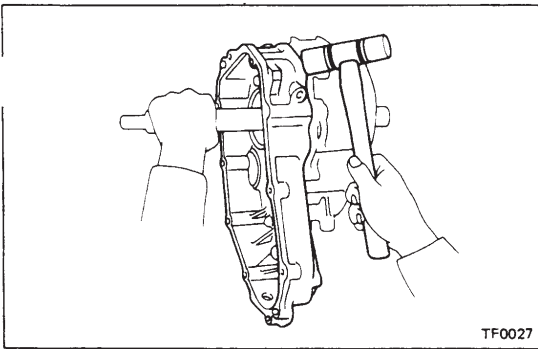

- (b) Using a plastic hammer, remove the front case with the output shaft.

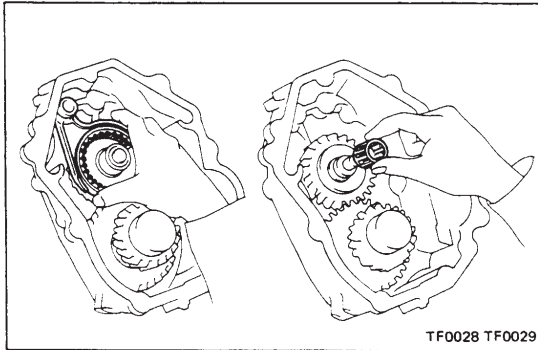

**22. REMOVE NO. 2 FORK WITH CLUTCH SLEEVE AND NEEDLE ROLLER BEARING FROM INPUT SHAFT**

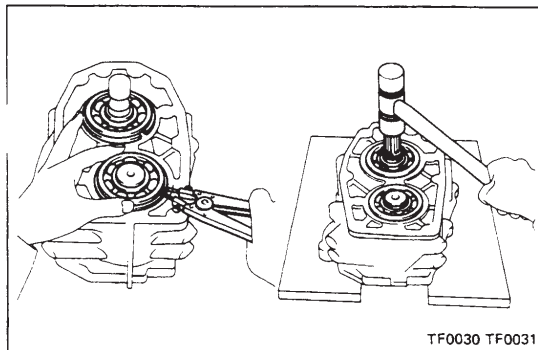

**23. REMOVE INPUT GEAR AND COUNTER GEAR FROM REDUCTION GEAR CASE**

- (a) Using snap ring pliers, remove the two snap rings.  
 (b) Using a plastic hammer, tap out the input gear and counter gear from the reduction gear case.

**NOTE:** Place the reduction gear case on something soft such as wooden blocks.

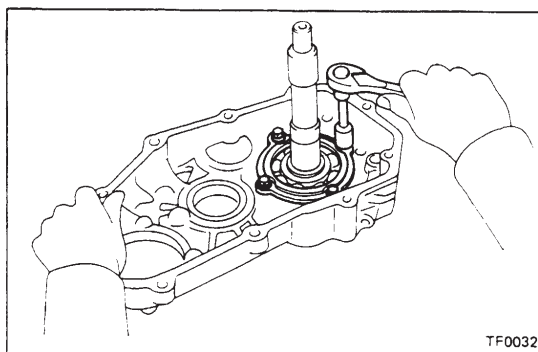

**24. REMOVE OUTPUT SHAFT FROM FRONT CASE**

- (a) Remove the four bearing retainer bolts and remove the bearing retainer.

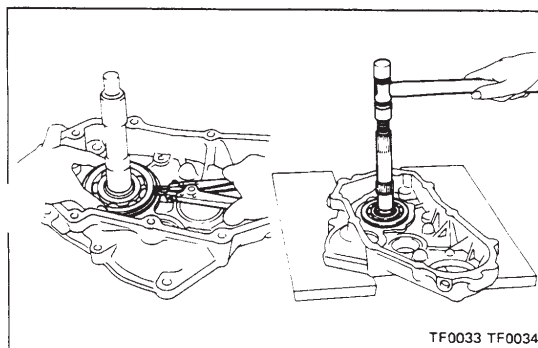

- (b) Using snap ring pliers, remove the snap ring.  
 (c) Using a plastic hammer, tap out the output shaft from the front case.

**NOTE:** Place the front case on something soft such as wooden blocks.

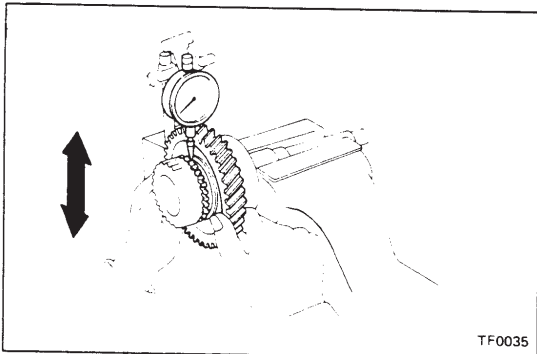

TF0035

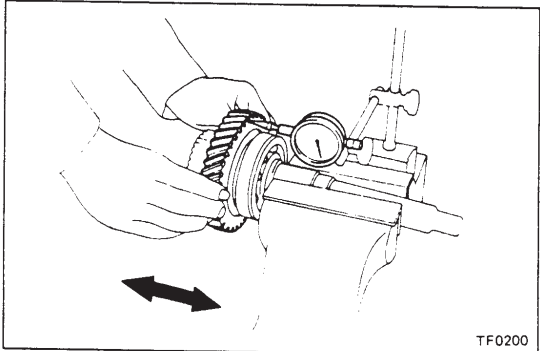

TF0200

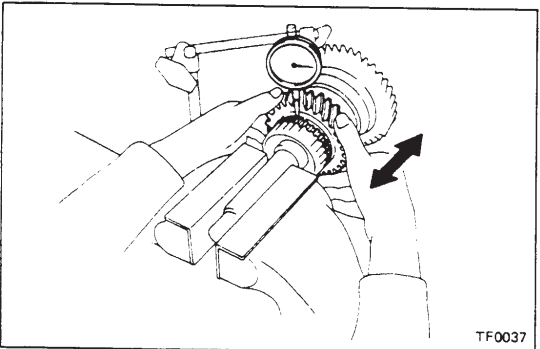

TF0037

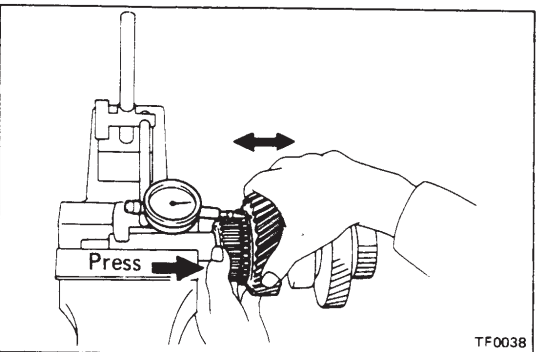

TF0038

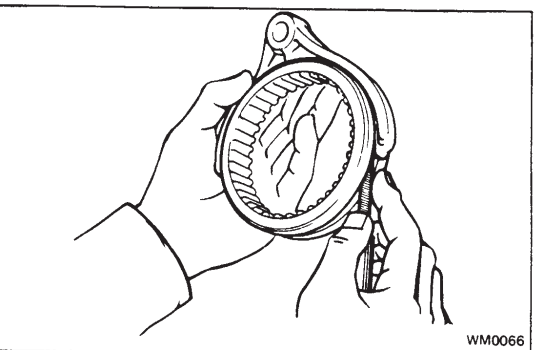

WM0066

## INSPECTION OF TRANSFER COMPONENTS

### 1. CHECK OIL CLEARANCE AND THRUST CLEARANCE TRANSFER LOW GEAR

- (a) Using a dial indicator, measure the oil clearance between the gear and shaft with the needle roller bearing installed.

**Standard clearance:** 0.010 — 0.055 mm  
(0.0004 — 0.0022 in.)

**Maximum clearance:** 0.075 mm  
(0.0030 in.)

- (b) Using a dial indicator, measure the thrust clearance with the spacer and bearing installed.

**NOTE:** Do not touch the shaft end of the dial indicator to the sub gear.

**Standard clearance:** 0.10 — 0.25 mm  
(0.0039 — 0.0098 in.)

**Maximum clearance:** 0.30 mm  
(0.0118 in.)

### 2. CHECK OIL CLEARANCE AND THRUST CLEARANCE OF TRANSFER DRIVE GEAR

- (a) Using a dial indicator, measure the oil clearance between the gear and shaft with the needle roller bearing installed.

**Standard clearance:** 0.009 — 0.051 mm  
(0.0004 — 0.0020 in.)

**Maximum clearance:** 0.071 mm  
(0.0028 in.)

- (b) Using a dial indicator, measure the thrust clearance with the clutch hub and spacer installed.

**Standard clearance:** 0.09 — 0.27 mm  
(0.0035 — 0.0106 in.)

**Maximum clearance:** 0.32 mm  
(0.0126 in.)

### 3. MEASURE CLEARANCE OF SHIFT FORKS AND HUB SLEEVES

Using a feeler gauge, measure the clearance between the hub sleeve and shift fork.

**Maximum clearance:** 1.0 mm (0.039 in.)

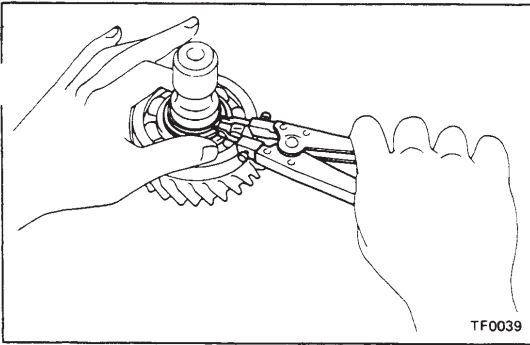

#### 4. INSPECT INPUT GEAR AND BEARING

Check for wear or damage.

#### 5. IF NECESSARY, REPLACE INPUT GEAR BEARING

(a) Using snap ring pliers, remove the snap ring.

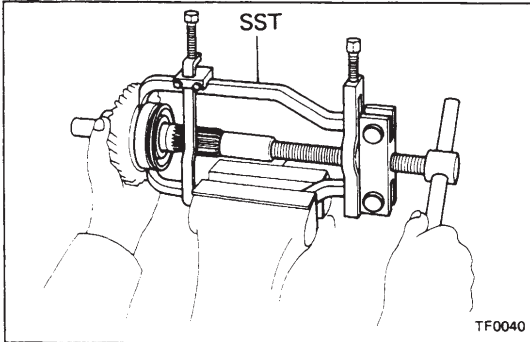

(b) Using SST, remove the bearing.

SST 09950-20015

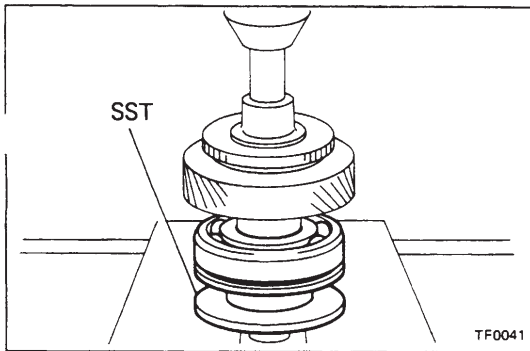

(c) Using SST, press in a new bearing.

SST 09316-60010

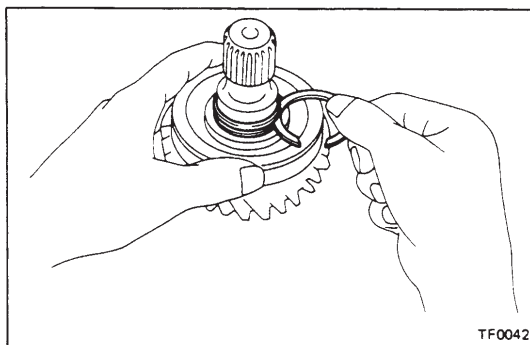

(d) Select a snap ring that will allow minimum axial play and install it on the shaft.

**Maximum play: 0.15 mm (0.0059 in.)**

Mark	Thickness	mm (in.)
1	2.05 – 2.10	(0.0807 – 0.0827)
3	2.15 – 2.20	(0.0846 – 0.0866)
5	2.25 – 2.30	(0.0886 – 0.0906)

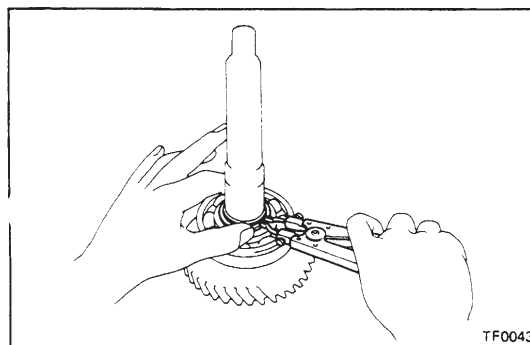

#### 6. INSPECT OUTPUT SHAFT AND BEARING

Check for wear and damage.

#### 7. IF NECESSARY, REPLACE OUTPUT SHAFT FRONT BEARING, LOW GEAR AND SUB GEAR

(a) Using snap ring pliers, remove the snap ring.

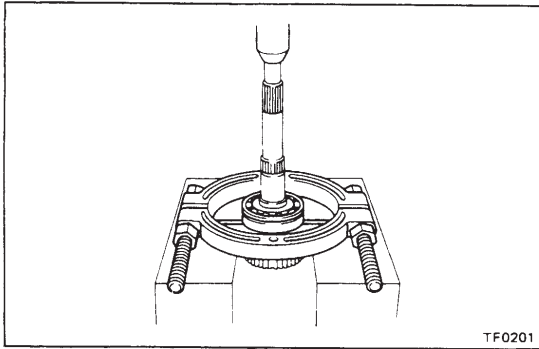

- (b) Using a press, remove the bearing, No.1 spacer and low gear.
- (c) Remove the steel ball and needle roller bearing.

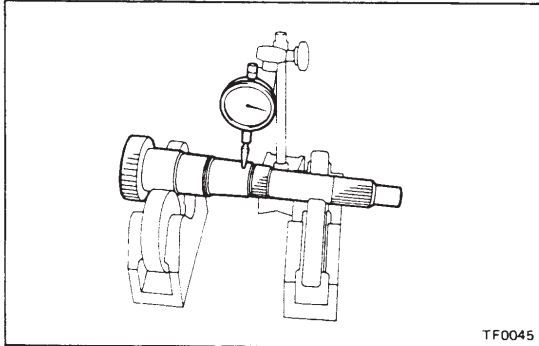

- (d) Using a dial indicator, measure the shaft runout.  
**Maximum runout: 0.03 mm (0.0012 in.)**

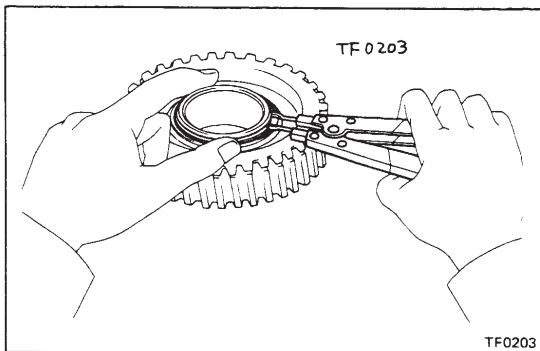

- (e) Using snap ring pliers, remove the snap ring from the low gear.
- (f) Remove the spacer, thrust spring and sub gear.
- (g) Install the sub gear, thrust spring and spacer.
- (h) Using snap ring pliers, install the snap ring.

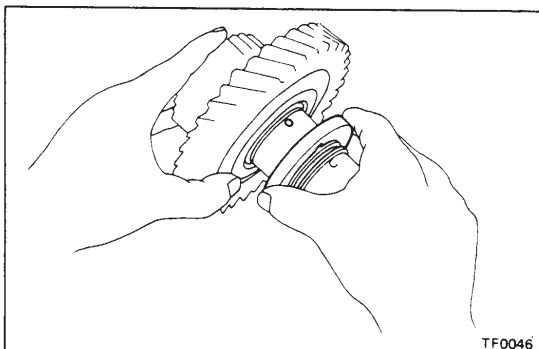

- (i) Apply MP grease to the needle roller bearing.
- (j) Install the low gear with needle roller bearing to the output shaft.
- (k) Install the steel ball on the output shaft.
- (l) Install the No.1 spacer.

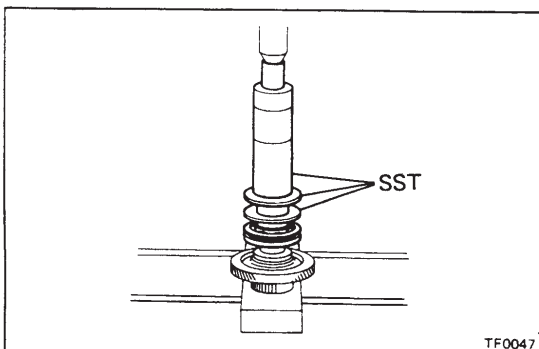

- (m) Using a press and SST, install the new bearing.  
**SST 09316-60010**

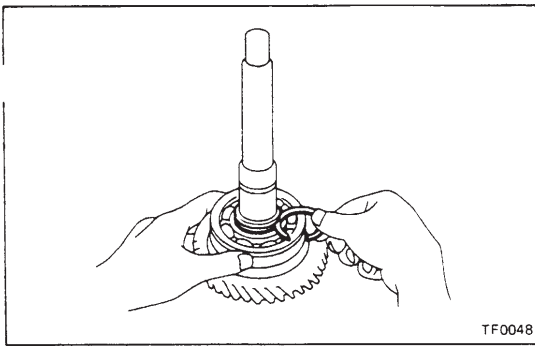

- (n) Select a snap ring that will allow minimum axial play and install it on the shaft.

**Maximum play: 0.10 mm (0.0039 in.)**

Mark	Thickness	mm (in.)
0	2.40 – 2.45	(0.0945 – 0.0965)
1	2.45 – 2.50	(0.0965 – 0.0984)
2	2.50 – 2.55	(0.0984 – 0.1004)
3	2.55 – 2.60	(0.1004 – 0.1024)
4	2.60 – 2.65	(0.1024 – 0.1043)
5	2.65 – 2.70	(0.1043 – 0.1063)

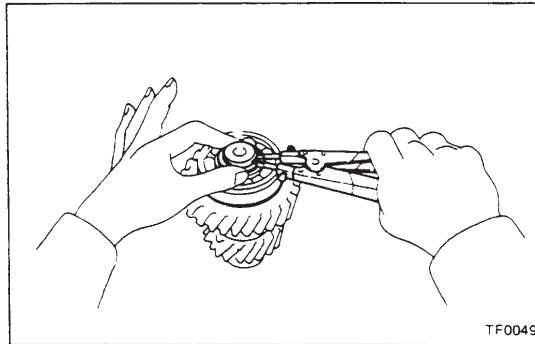

## 8. INSPECT COUNTER GEAR AND BEARING

Check for wear or damage.

## 9. IF NECESSARY, REPLACE COUNTER GEAR FRONT BEARING AND SUB GEAR

- (a) Using snap ring pliers, remove the snap ring.

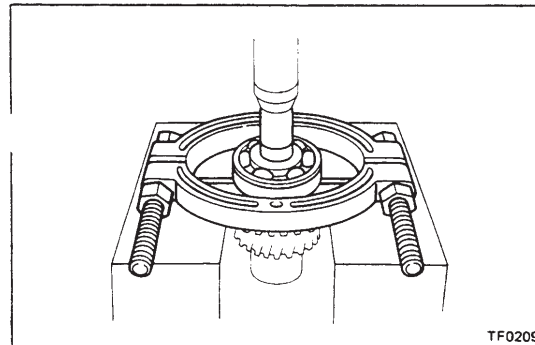

- (b) Using SST and a press, remove the bearing.

SST 09950-00020

- (c) Remove the spacer, thrust spring and sub gear.

- (d) Install the sub gear, thrust spring and spacer on the counter gear.

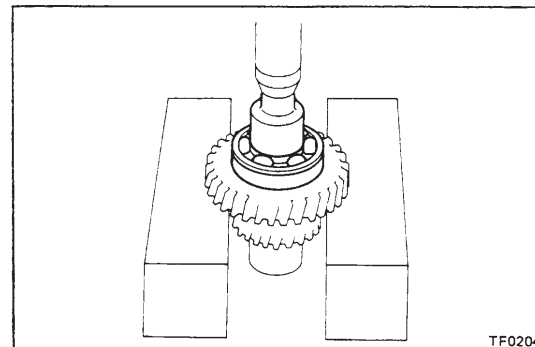

- (e) Using a press and 32 mm socket wrench, install the bearing.

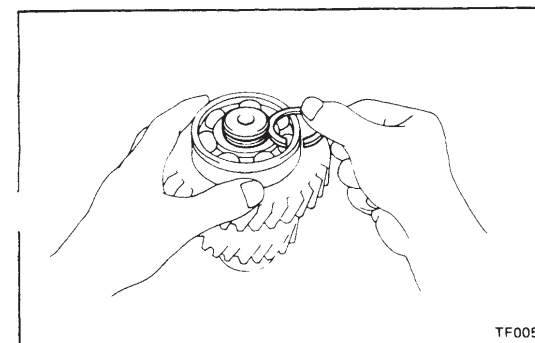

- (f) Select a snap ring that will allow minimum axial play and install it on the shaft.

**Maximum play: 0.15 mm (0.0059 in.)**

Mark	Thickness	mm (in.)
1	2.10 – 2.15	(0.0827 – 0.0846)
3	2.20 – 2.25	(0.0866 – 0.0886)

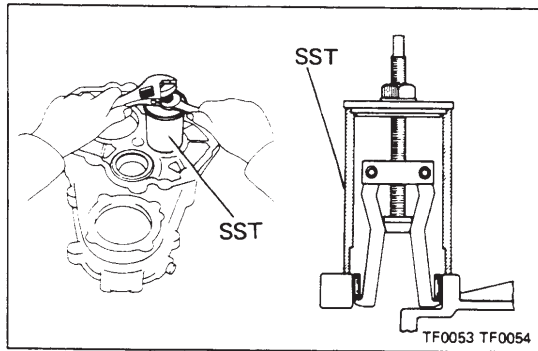

#### 10. IF NECESSARY, REPLACE COUNTER GEAR REAR BEARING

- (a) Using SST, remove the bearing.  
SST 09612-30012

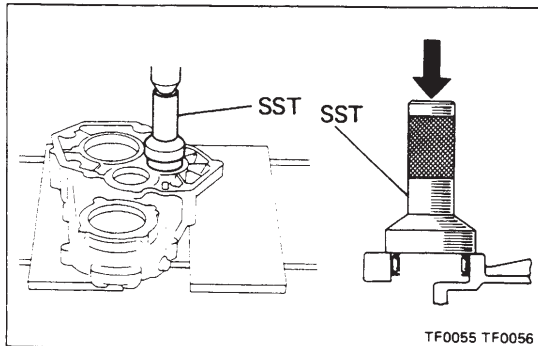

- (b) Using SST, press in a new bearing.  
SST 09310-35010

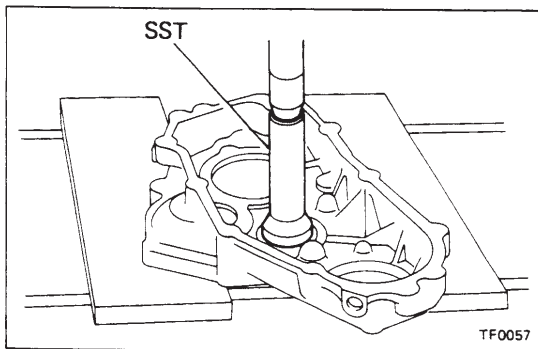

#### 11. INSPECT IDLER GEAR AND BEARING

Check for wear or damage.

#### 12. IF NECESSARY, REPLACE IDLER GEAR FRONT BEARING

- (a) Using SST, press out the bearing.  
SST 09310-35010

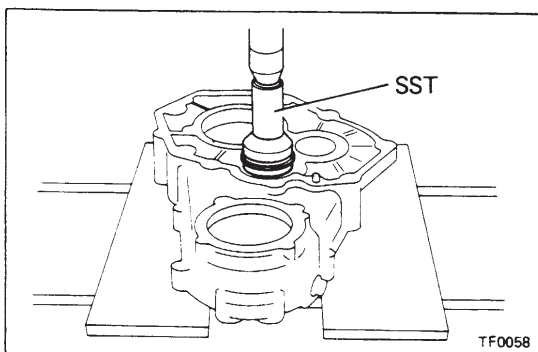

- (b) Using SST, press in a new bearing up to the position of the snap ring.  
SST 09310-35010

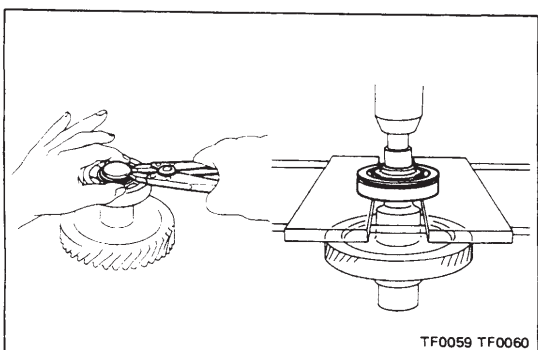

#### 13. IF NECESSARY, REPLACE IDLER GEAR REAR BEARING

- (a) Using snap ring pliers, remove the snap ring.  
(b) Press out the bearing.



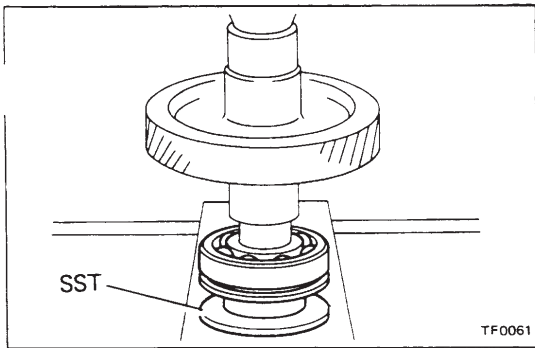

(c) Using SST, press in a new bearing.  
SST 09316-60010

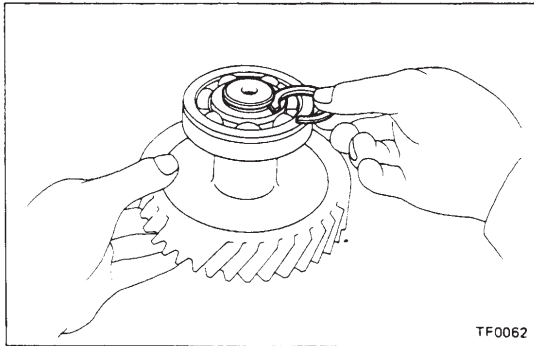

(d) Select a snap ring that will allow minimum axial play and install it on the shaft.

**Maximum play: 0.15 mm (0.0059 in.)**

Mark	Thickness	mm (in.)
A	1.50 — 1.55	(0.0591 — 0.0610)
B	1.60 — 1.65	(0.0630 — 0.0650)

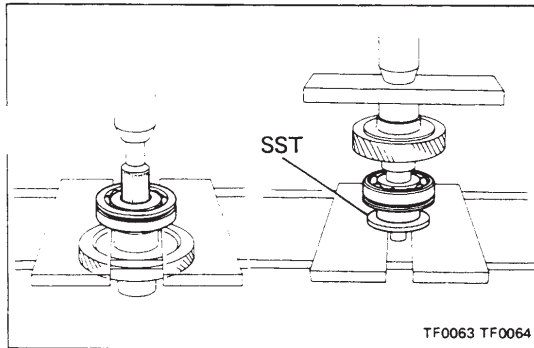

**14. INSPECT FRONT DRIVE GEAR AND BEARING**

Check for wear or damage.

**15. IF NECESSARY, REPLACE FRONT DRIVE GEAR FRONT BEARING**

- (a) Press out the bearing.
- (b) Using SST, press in a new bearing.  
SST 09316-60010

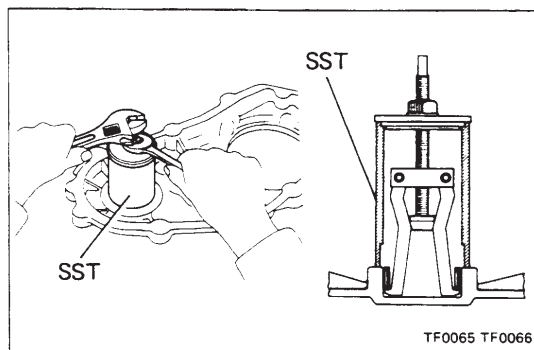

**16. IF NECESSARY, REPLACE FRONT DRIVE GEAR REAR BEARING**

- (a) Using SST, remove the bearing.  
SST 09612-30012

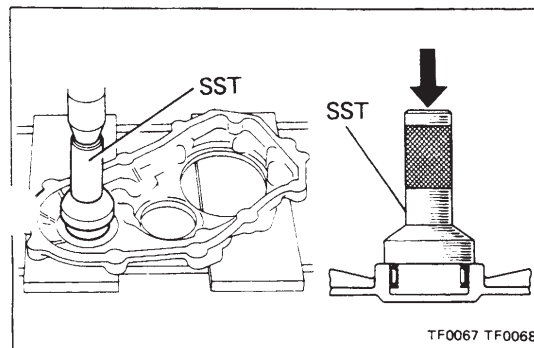

- (b) Using SST, press in a new bearing.  
SST 09310-35010

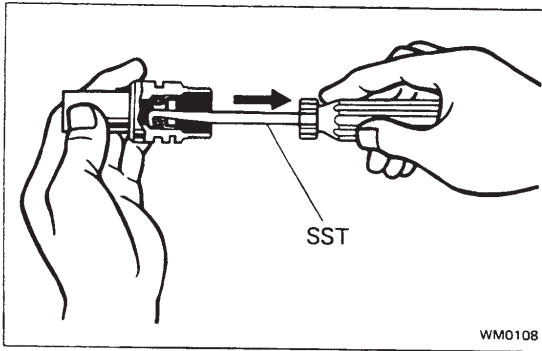

**17. INSPECT SPEEDOMETER DRIVEN GEAR OIL SEAL**

- (a) Check for damage.
- (b) Check the oil seal lip for wear or damage.

**18. IF NECESSARY, REPLACE SPEEDOMETER DRIVEN GEAR OIL SEAL**

- (a) Using SST, pull out the oil seal.  
SST 09921-00010

- (b) Using SST, drive a new oil seal into the sleeve.

SST 09201-60011

Oil seal depth: 20 mm (0.79 in.)

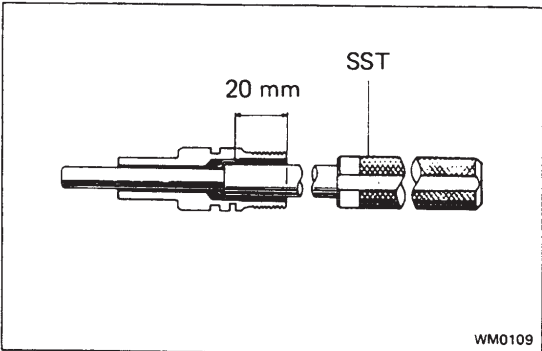

**19. INSPECT EXTENSION HOUSING OIL SEAL**

- (a) Check for damage.
- (b) Check the oil seal lip for wear or damage.

**20. IF NECESSARY, REPLACE EXTENSION HOUSING OIL SEAL**

- (a) Using SST, remove the two oil seals.  
SST 09308-00010

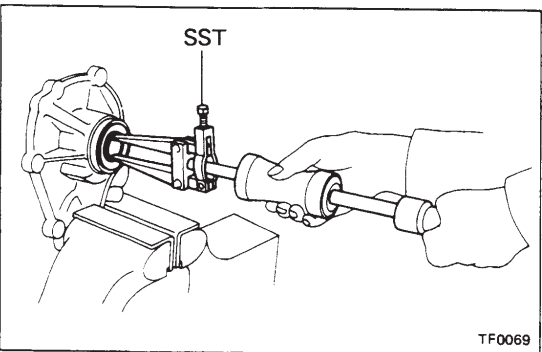

- (b) Using SST, drive in a new oil seal.

SST 09310-35010

NOTE: When assembling a new oil seal for the oil pump screw, position the flat surface upward.

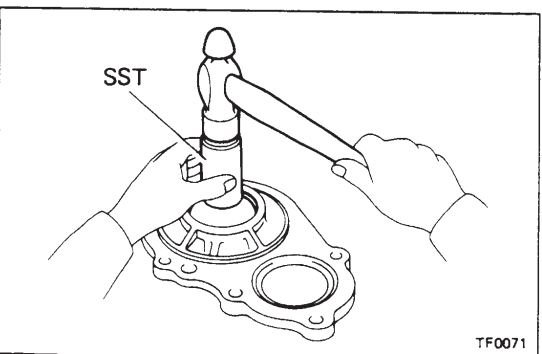

- (c) Using SST, drive in a new oil seal.

SST 09325-20010

NOTE: Take note of the groove direction and be careful not to interchange this seal with the front drive gear oil seal. This oil seal has one arrow mark pointing counterclockwise to distinguish it from the front drive gear oil seal.

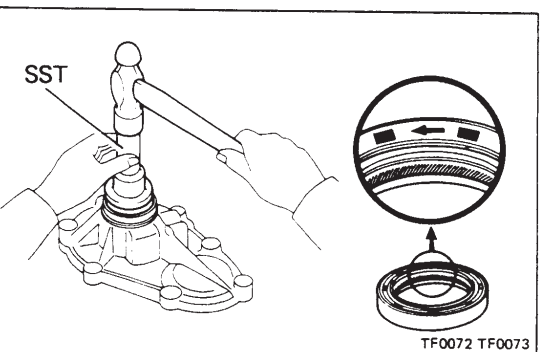

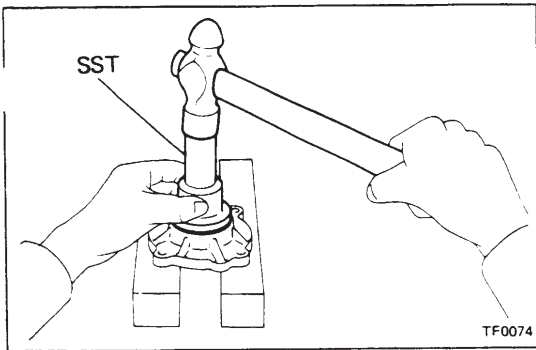

## 21. INSPECT FRONT DRIVE GEAR OIL SEAL

- (a) Check for damage.
- (b) Check the oil seal lip for wear or damage.

## 22. IF NECESSARY, REPLACE FRONT DRIVE GEAR OIL SEAL

- (a) Using SST, drive out the oil seal and dust cover.

SST 09325-20010

NOTE: Place the bearing retainer on something soft such as wooden blocks.

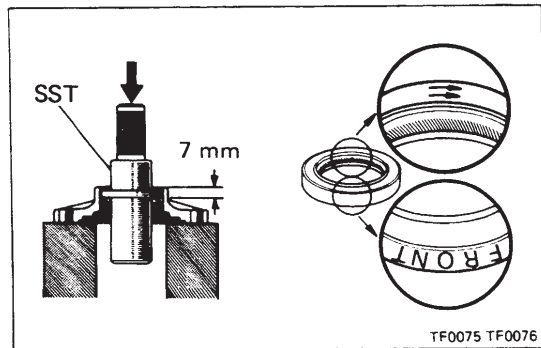

- (b) Using SST, drive in a new oil seal to a depth of 7 mm (0.28 in.) from the end.

SST 09325-20010

NOTE: Take note of the groove direction and be careful not to interchange this seal with the output shaft oil seal. This oil seal has two arrow marks pointing clockwise and the word FRONT to distinguish it from the output shaft.

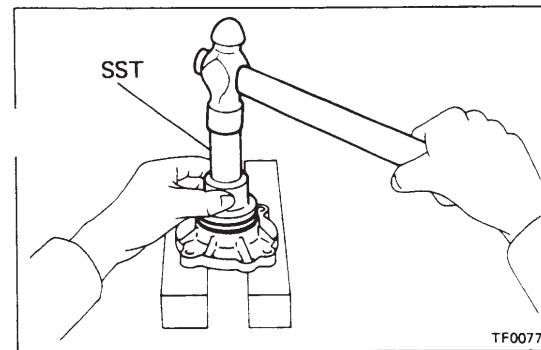

- (c) Using SST, drive in a new dust cover.

SST 09325-20010

## 23. INSPECT TRANSFER INDICATOR SWITCH

Using an ohmmeter, check the continuity between both terminals when the plunger is pushed in.

If there is no continuity, replace the switch.

**ASSEMBLY OF TRANSFER**

(See pages TF-5, 6)

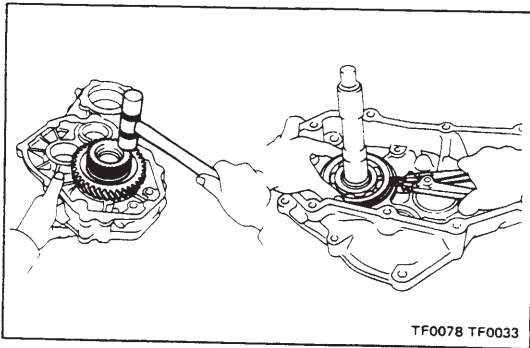
**1. INSTALL OUTPUT SHAFT TO FRONT CASE**

- (a) Using a plastic hammer, install the output shaft to the front case.

NOTE: Place the front case on something soft such as wooden blocks.

- (b) Using snap ring pliers, install the snap ring.

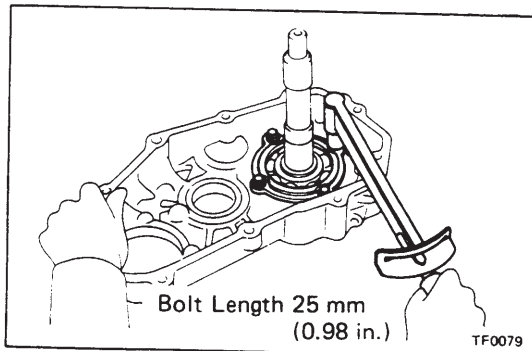
**2. INSTALL BEARING RETAINER TO FRONT CASE**

Install the bearing retainer with four bolts. Torque the bolts.

Torque: 130 kg-cm (9 ft-lb, 13 N·m)

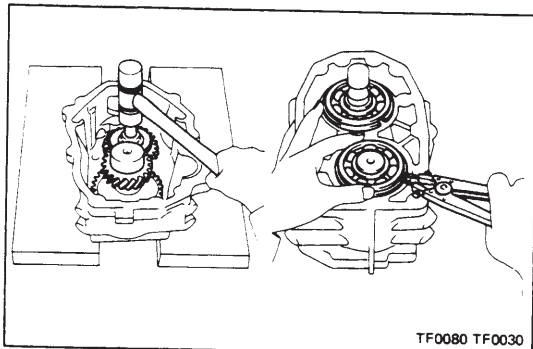
**3. INSTALL INPUT GEAR AND COUNTER GEAR TO REDUCTION GEAR CASE**

- (a) Using a plastic hammer, install the input gear and counter gear to the reduction gear case.

NOTE: Place the reduction gear case on something soft such as wooden blocks.

- (b) Using snap ring pliers, install the snap rings.

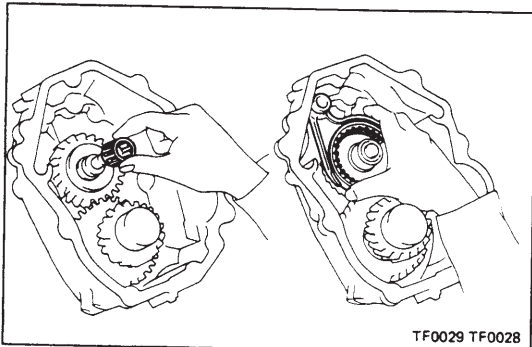
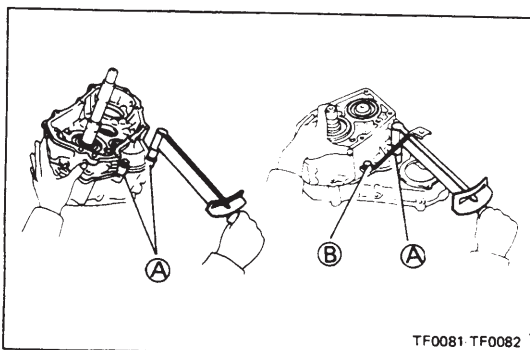
**4. INSTALL ROLLER BEARING ON INPUT SHAFT****5. INSTALL NO.2 HUB SLEEVE AND NO.2 SHIFT FORK ON INPUT SHAFT****6. INSTALL REDUCTION GEAR CASE WITH NEW GASKET TO FRONT CASE**

- (a) Place a new gasket on the front case.
- (b) Install the reduction gear case together with the input gear and counter gear.
- (c) Install and torque the bolts as shown in the figure.

Torque:

Ⓐ Bolt length 47 mm (1.85 in.)  
400 kg-cm (29 ft-lb, 39 N·m)

Ⓑ Bolt length 49 mm (1.93 in.)  
400 kg-cm (29 ft-lb, 39 N·m)

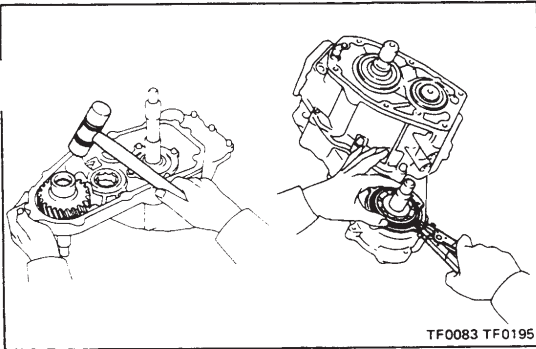

## 7. INSTALL FRONT DRIVE GEAR

- (a) Using a plastic hammer, install the front drive gear.
- (b) Using snap ring pliers, install the snap ring.

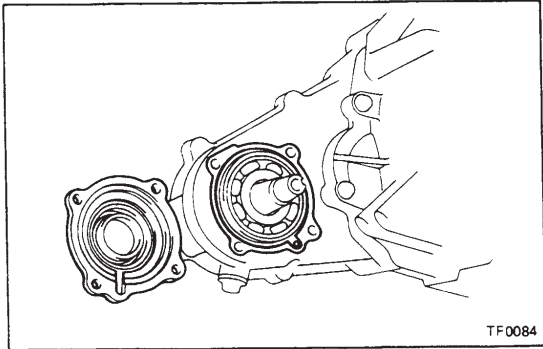

## 8. INSTALL BEARING RETAINER WITH NEW GASKET

- (a) Place a new gasket on the front case.
- (b) Apply MP grease to the oil seal.
- (c) Install the bearing retainer.

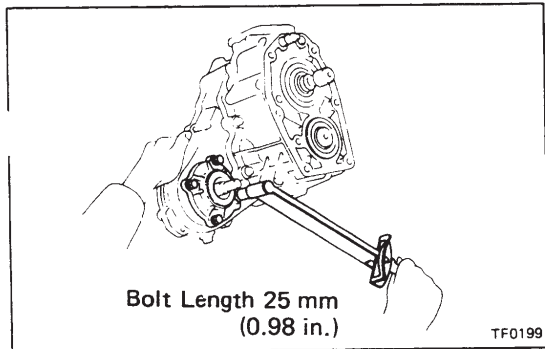

- (d) Install and torque the bolts.

**Torque: 195 kg-cm (14 ft-lb, 19 N·m)**

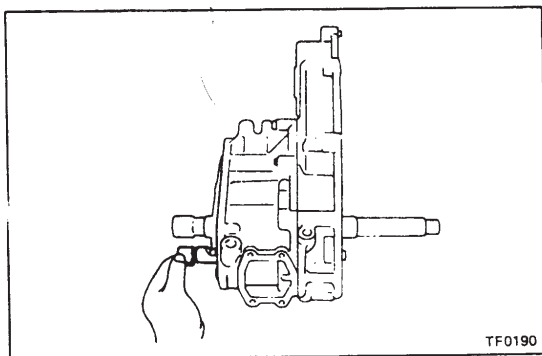

## 9. INSTALL HIGH-LOW SHIFT FORK SHAFT

Insert the high-low shift fork shaft to the No.2 shift fork.

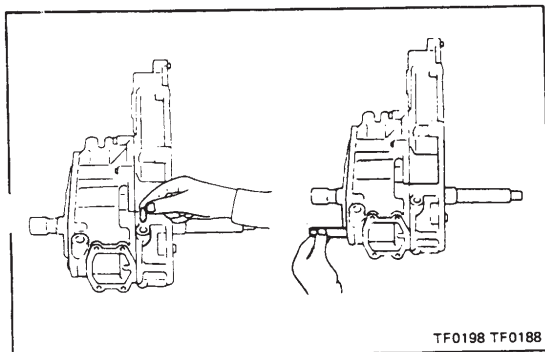

## 10. INSTALL INTERLOCK PIN AND FRONT DRIVE SHIFT FORK SHAFT

- (a) Install the interlock pin.
- (b) Install the front drive shift fork shaft with the two grooves facing outward.

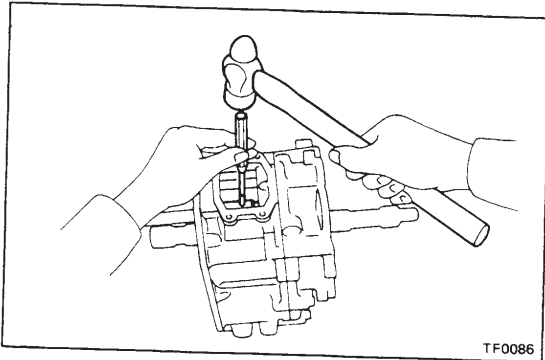

TF0086

### 11. INSTALL SLOTTED SPRING PINS

- (a) Align slotted spring holes in the forks with the holes in the shafts.
- (b) Using a pin punch, drive in slotted spring pins.

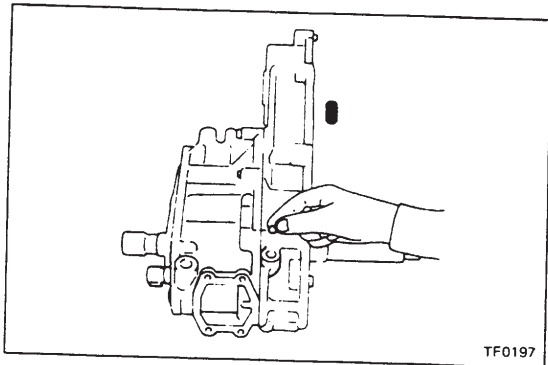

TF0197

### 12. INSTALL TWO BALLS, SPRINGS AND PLUGS

- (a) Install the ball and spring.

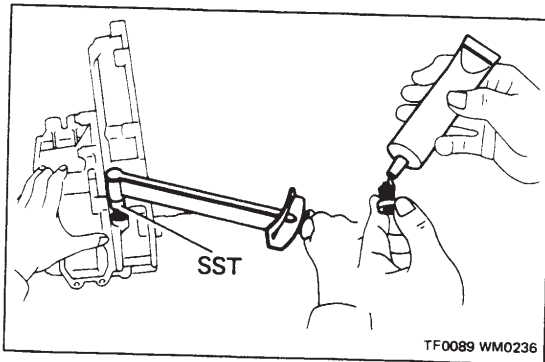

TF0089 WM0236

- (b) Apply liquid sealer to the screw or the plug.

- (c) Using SST, install and torque the plug.

SST 09313-30021

Torque: 130 kg-cm (9 ft-lb, 13 N·m)

- (d) Install the ball, spring and plug to the opposite side.

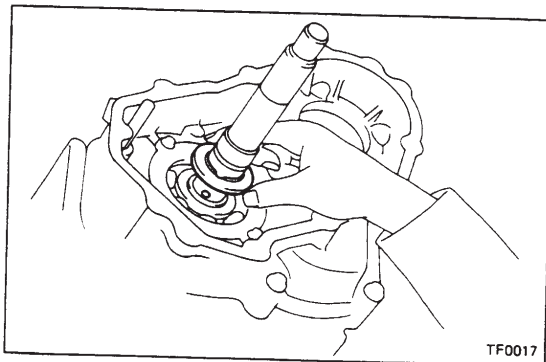

TF0017

### 13. INSTALL LOCKING BALL AND NO.2 SPACER

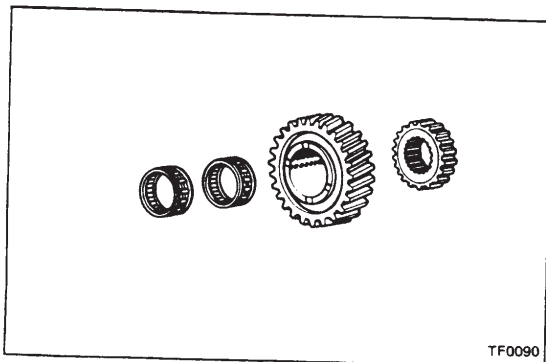

TF0090

### 14. INSTALL NEEDLE ROLLER BEARINGS, TRANSFER LOWER GEAR AND CLUTCH HUB

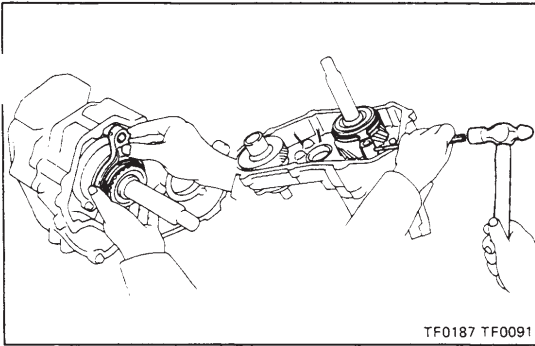

### 15. INSTALL NO.1 SHIFT FORK AND HUB SLEEVE

- Install the No.1 shift fork together with the hub sleeve to the front drive shift fork shaft.
- Align the slotted pin hole in the fork with the hole in the shaft.
- Using a pin punch and hammer, install the slotted spring pin.

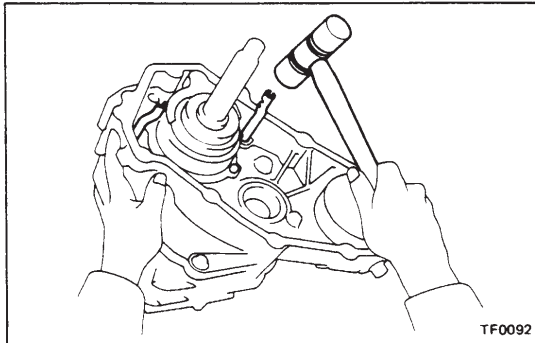

### 16. INSTALL OIL PIPES

Install the two oil pipes with the cutout side positioned upward.

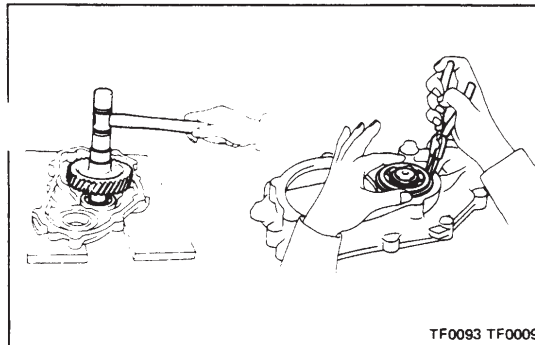

### 17. INSTALL IDLER GEAR TO REAR CASE

- Using a plastic hammer, install the idler gear to the rear case.
- NOTE: Place the rear case on something soft such as wooden blocks.
- Using snap ring pliers, install the snap ring.

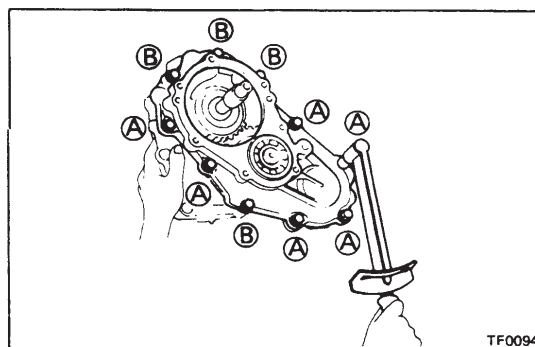

### 18. INSTALL REAR CASE WITH NEW GASKET

- Place a new gasket on the front case.
- Install the rear case together with the idler gear.
- Install and torque the bolts as shown in the figure.

Torque:

- |               |                              |
|---------------|------------------------------|
| Ⓐ Bolt length | 47 mm (1.85 in.)             |
|               | 400 kg-cm (29 ft-lb, 39 N·m) |
| Ⓑ Bolt length | 112 mm (4.41 in.)            |
|               | 400 kg-cm (29 ft-lb, 39 N·m) |

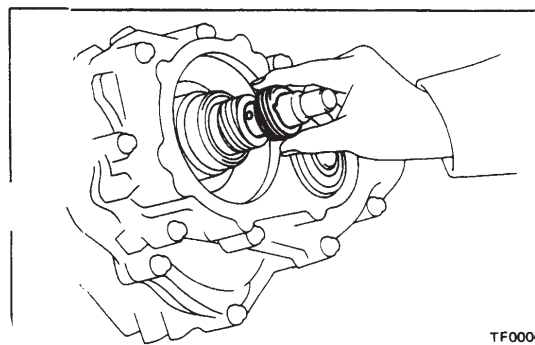

### 19. INSTALL BEARING, OIL PUMP SCREW, LOCKING BALL AND SPEEDOMETER DRIVE GEAR

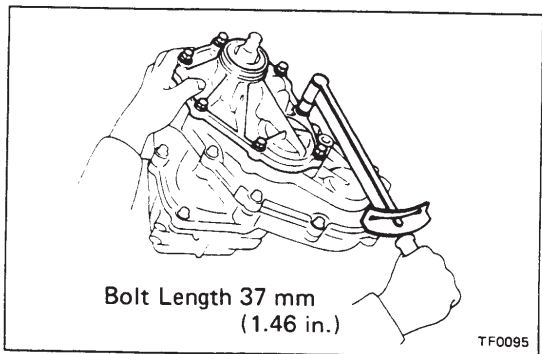

## 20. INSTALL EXTENSION HOUSING WITH NEW GASKET

- Place a new gasket to the rear case.
- Apply MP grease to the two oil seals.
- Install the extension housing with seven bolts. Torque the bolts.

**Torque: 400 kg-cm (29 ft-lb, 39 N·m)**

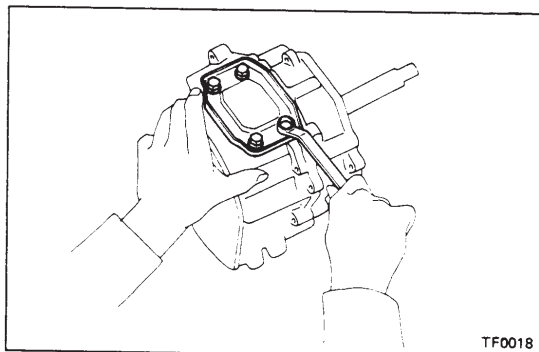

## 21.-1 (22R Engine Vehicle) INSTALL TRANSFER CASE COVER

**Torque: 90 kg-cm (78 in.-lb, 8.8 N·m)**

## 21.-2 (22R-EC Engine Vehicle) INSTALL SHIFT LEVER RETAINER

**Torque: 130 kg-cm (9 ft-lb, 13 N·m)**

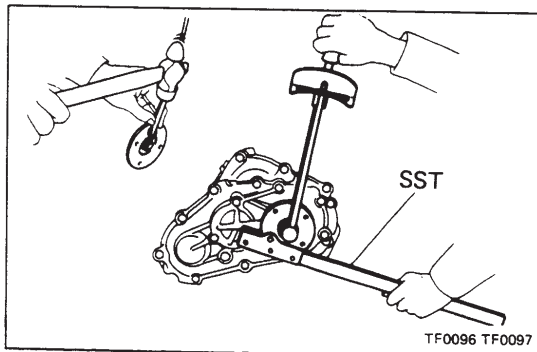

## 22. INSTALL REAR COMPANION FLANGE

- Install the companion flange to the output shaft.
- Using SST to hold the flange, install the washer and nut. Torque the nut.

SST 09330-00020

**Torque: 1,250 kg-cm (90 ft-lb, 123 N·m)**

- Stake the nut.

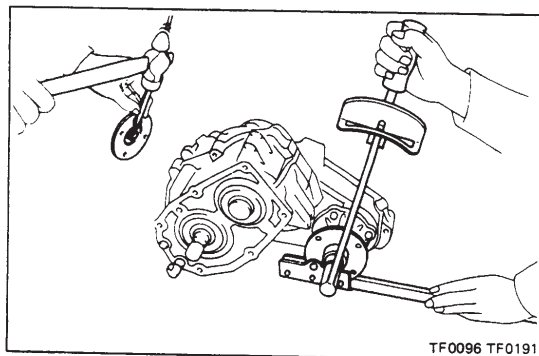

## 23. INSTALL FRONT COMPANION FLANGE

- Install the companion flange to the front drive gear.
- Using SST to hold the flange, install the washer and nut. Torque the nut.

SST 09330-00020

**Torque: 1,250 kg-cm (90 ft-lb, 123 N·m)**

- Stake the nut.

## 24. INSTALL TRANSFER INDICATOR SWITCH WITH WASHER

## 25. INSTALL SPEEDOMETER DRIVEN GEAR

Secure the gear with the lock plate and bolt.



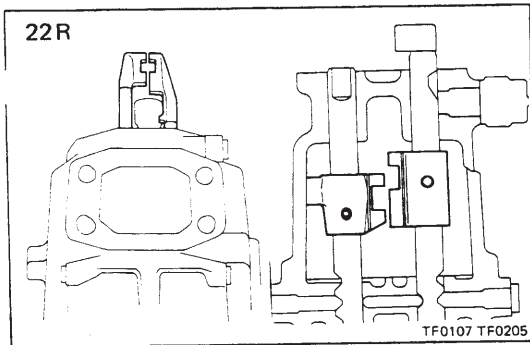

## INSTALLATION OF TRANSFER

### 1. INSTALL TRANSFER AND PROPELLER SHAFT UPPER DUST COVER TO TRANSMISSION WITH NEW GASKET

- (a) Shift the two shift fork shafts to the high-four position.

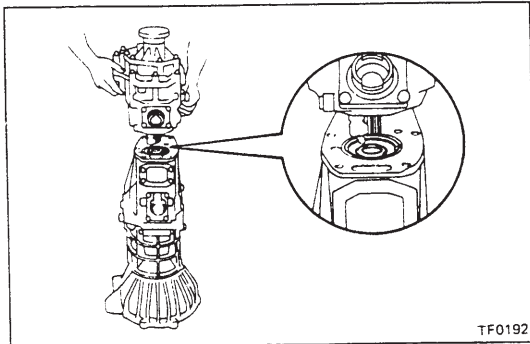

- (b) Apply MP grease to the adapter oil seal.

- (c) Place a new gasket to the transfer adapter.

- (d) Install the transfer to the transmission.

NOTE: Take care not to damage the oil seal by the input gear spline when installing the transfer.

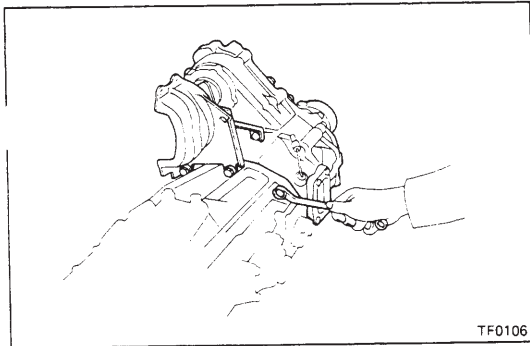

- (e) Install and torque the bolts with the propeller shaft upper dust cover.

**Torque: 400 kg-cm (29 ft-lb, 39 N·m)**

- (f) Install the dust cover bolts to the bracket.

NOTE: There are two bolt lengths; 43 mm (used for the dust cover) and 39 mm.

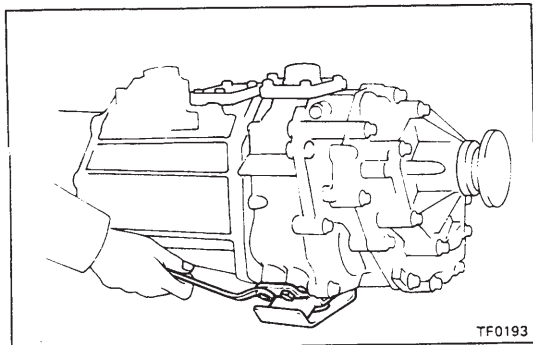

### 2. INSTALL ENGINE REAR MOUNTING

**Torque: 260 kg-cm (19 ft-lb, 25 N·m)**

### 3. PLACE TRANSMISSION WITH TRANSFER AT INSTALLATION POSITION

- (a) Support the transmission with a jack.
- (b) Align the input shaft spline with the clutch disc, and push the transmission with the transfer fully into position.

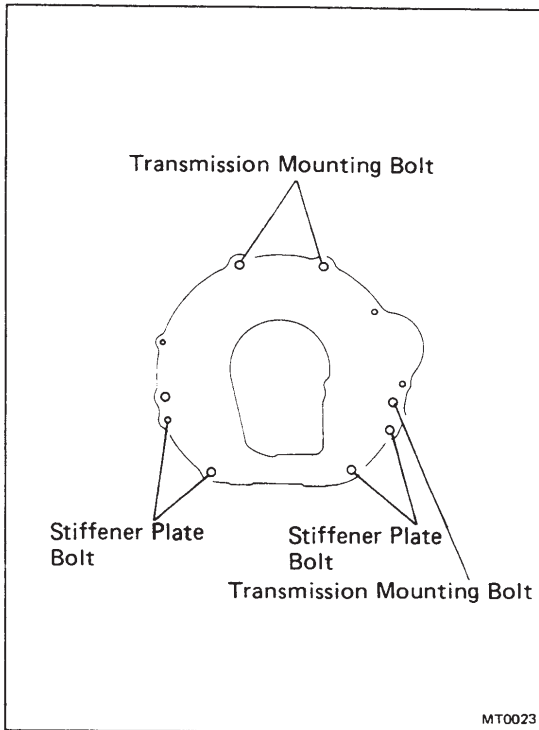

#### 4. INSTALL TRANSMISSION BOLTS AND STIFFENER BOLTS

##### Torque:

**Transmission Mounting Bolt**  
730 kg-cm ( 53 ft-lb, 72 N·m)

**Stiffener plate Bolt**  
380 kg-cm ( 27 ft-lb, 37 N·m)

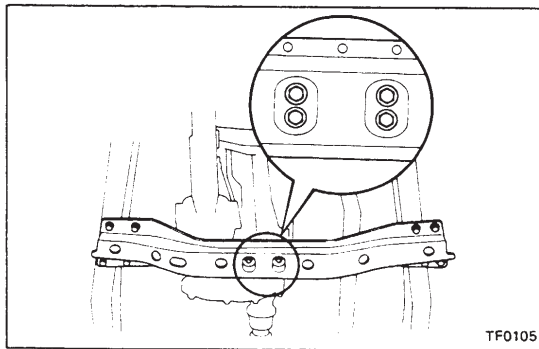

#### 5. INSTALL FRAME CROSSMEMBER NO.2

- Raise the transmission slightly with a jack.
- Install the frame crossmember No.2 to the side frame with the bolts.  
Torque the bolts.

**Torque: 970 kg-cm (70 ft-lb, 95 N·m)**

- Lower the transmission and transfer.
- Install the four mounting bolts to the engine rear mounting. Torque the bolts.

**Torque: 130 kg-cm (9 ft-lb, 13 N·m)**

#### 6. REMOVE PIECE OF WOOD FROM FRONT AXLE

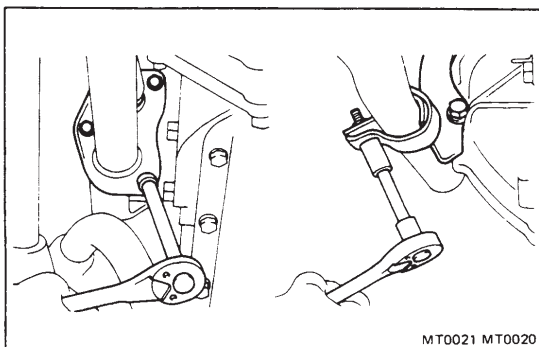

#### 7. INSTALL EXHAUST PIPE, BRACKET AND PIPE

- Install the exhaust pipe to the manifold.
- Install the pipe bracket to the clutch housing. Torque the bolts.

**Torque: Upper 380 kg-cm (27 ft-lb, 37 N·m)**  
**Lower 700 kg-cm (51 ft-lb, 69 N·m)**

- Install the exhaust pipe clamp.

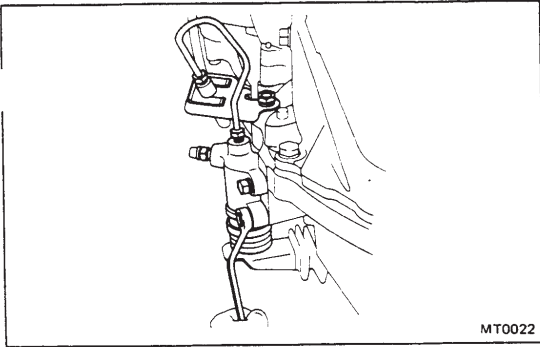

8. **INSTALL STARTER LOWER MOUNTING BOLT AND RELEASE CYLINDER TUBE BRACKET**

9. **INSTALL CLUTCH RELEASE CYLINDER**

Torque: 120 kg-cm (9 ft-lb, 12 N·m)

10. **CONNECT SPEEDOMETER CABLE, BACK-UP LIGHT SWITCH CONNECT AND TRANSFER INDICATOR SWITCH CONNECTOR**

11. **CONNECT PROPELLER SHAFT**  
(See page PR-11)

12. **FILL TRANSMISSION AND TRANSFER WITH OIL**

Oil type: API GL-4 or GL-5 SAE 75W90 or 80W90

Quantity:

Transmission

3.9 liters (4.1 US qts, 3.4 Imp. qts)

Transfer

1.6 liters (1.7 US qts, 1.4 Imp. qts)

13. **LOWER VEHICLE**

14. **INSTALL STARTER UPPER MOUNTING NUT**

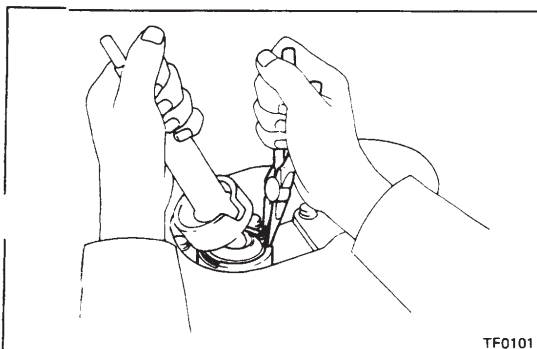

15. **INSTALL TRANSFER SHIFT LEVER**

(a) Apply MP grease to the transfer shift lever.

(b) Using pliers, install the shift lever.

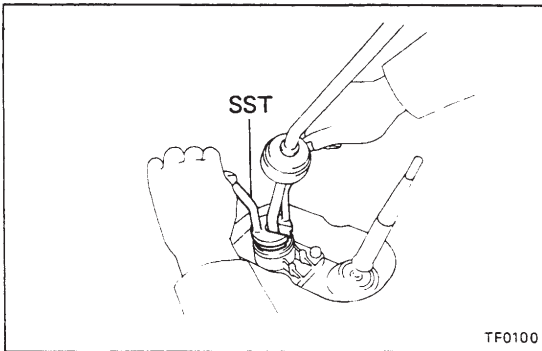
**16. INSTALL TRANSMISSION SHIFT LEVER**

- (a) Apply MP grease to the transmission shift lever.
- (b) (22R Engine Vehicle)  
Using SST, install the shift lever.

SST 09305-20012

(22R-EC Engine Vehicle)  
Install the shift lever with four bolts.

**17. CONNECT BATTERY CABLE TO NEGATIVE TERMINAL****18. PERFORM ROAD TEST**

Check for abnormal noise and smooth operation.